

ADVANCED INTERCONNECTIONS®

5 Energy Way, P.O. Box 1019, West Warwick, RI 02893

® Tel. 800-424-9850 / 401-823-5200 • Fax 401-823-8723 • Email advintcorp@aol.com • Internet http://www.advintcorp.com

BGA Sockets/Adapters

Adapters

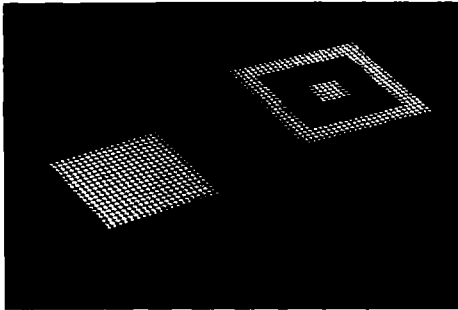

Extraction Slot Adapter

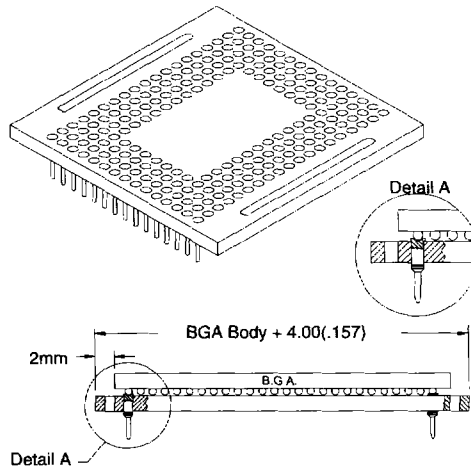

Standard Adapter

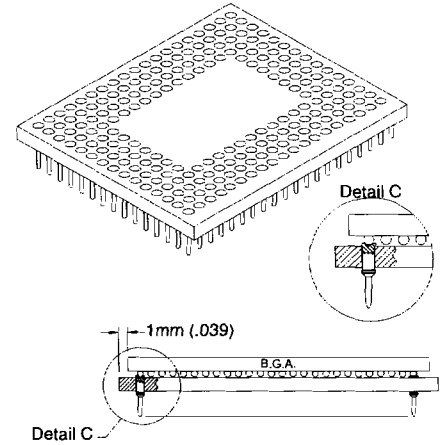

Terminals:

Brass per QQ-B-626

Plating:

Terminal TL: Tin/Lead over Nickel
Terminal G: Gold over Nickel

Body Material:

FR-4 Glass Epoxy
U.L. Rated 94V-O

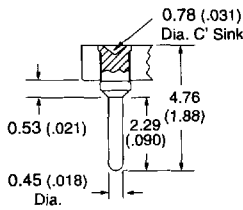

Type 567

How To Order

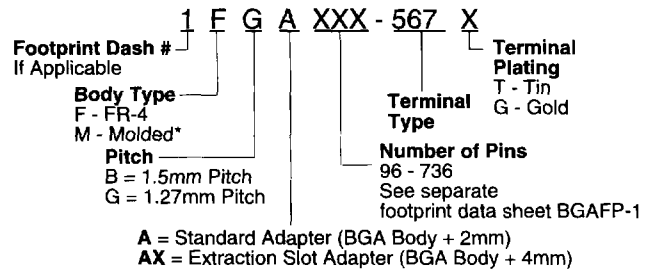

* Preliminary At This Time

Sockets

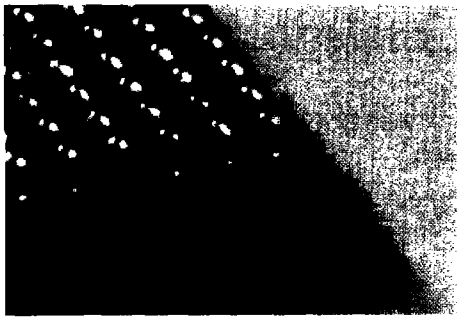

Terminal Type -604 Shown
Patent Pending

Type -551

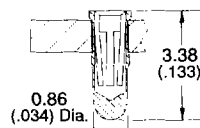

Type -565

With Solder Preform

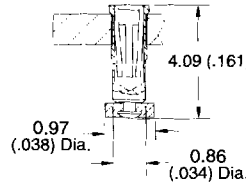

Type -553

Without Solder Preform

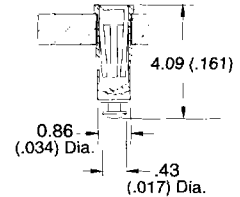

Type -618

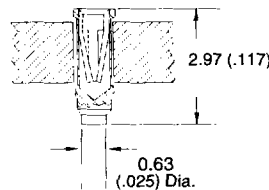

Type -604

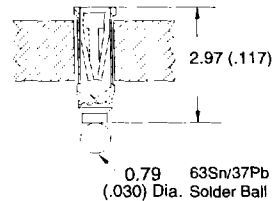

Type -614

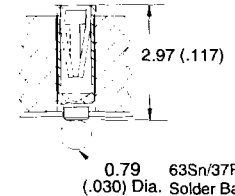

Terminals and Contacts:

Terminals: Brass per QQ-B-626
Contacts: Beryllium Copper per QQ-C-533

Plating:

Terminal TL: Tin/Lead over Nickel
Terminal G: Gold over Nickel

Body Material:

FR-4 Glass Epoxy
U.L. Rated 94V-O
Polyimide Film (Peel-A-Way®) Type -573 Only

Solder

63Sn/37Pb Solder Ball

* Preliminary At This Time

How To Order

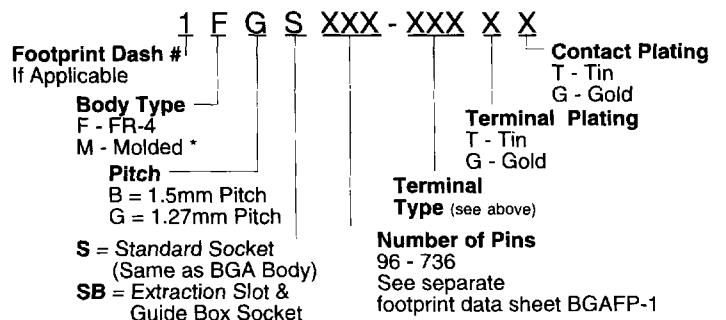

Available with Heat Sink Retention Features - Consult Factory.